



1. SCOPE

This specification shall cover the characteristics of crystal unit with
HC-49/S SMD 3.579545—27.00MHz

2. ELECTRICAL SPECIFICATION

ITEM	SPECIFICATION
HOLDER TYPE	HC-49/S SMD
NOMINAL FREQUENCY	3.579545—27.00MHz
LOAD CAPACITANCE	10PF to series
OSCILLATION MODE	Fundamental
FREQUENCY TOLERANCE AT 25°C ±2°C	± 30PPM
EQUIVALENT SERIES RESISTANCE	Based on frequency
DRIVE LEVEL	0.5MW
OPERATING TEMPERATURE RANGE	-10°C ~+60°C
FREQUENCY STABILITY	± 30PPM
SHUNT CAPACITANCE	7PF max
AGING	± 5PPM/YEAR
INSULATION RESISTANCE	>500M Ω at DC 100V

3. Dimension (mm)

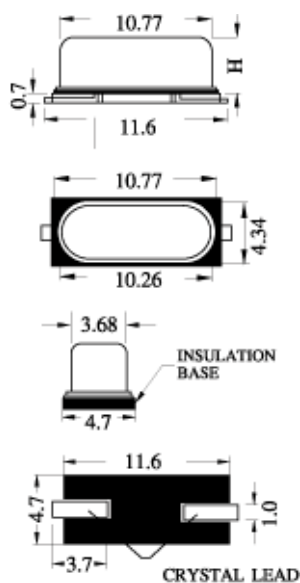

H=4.0mm

4. MECHANICAL SPECIFICATION

1) Terminal Strength

* Lead pulling test

Conditions:	Load	907.2 gram
	Direction	To the downward
	Duration of applied force	5 seconds
Results:	There should be no distortion in appearance.	

* Lead bending test

Conditions:	Load	453.6 gram
	Bending angle	90° to normal position
	Rate of bending	3 seconds in each cycle
	Number of bending	3
Results:	There should be no distortion in appearance.	

2) Lead solderability test

Conditions: Dipping in solder(+230°C ± 5°C)for 5 seconds
 Results: More than 95% of surface being tested should be coated uniformly with solder.

3) Vibration test

Conditions:	Frequency	10 – 55Hz
	Amplitude	0.762mm
	Sweep	1.0 minute
	Duration	2 hours
Results:	Frequency and wave form of tested products must Remain within specifications.	

4) Drop test

Conditions:	Method of drop	Natural drop
	Dropping floor	Hard wood board
	Height	30cm
	Number of drops	3 times
Results:	Frequency and wave form of tested products must remain within specifications.	

5. ENVIRONMENTAL SPECIFICATION

1) Temperature test

* Temperature cycling test

Conditions: Steps of cycle

- 1) At -55°C , 30 minutes
- 2) At $+25^{\circ}\text{C}$, 10 - 15 minutes
- 3) At $+85^{\circ}\text{C}$, 30 minutes
- 4) At $+25^{\circ}\text{C}$, 10 - 15 minutes

Number of cycles 3 times

Results: Frequency and wave form of tested products must remain within specifications.

* Low Temperature test

Conditions: Temperature $-20^{\circ}\text{C} \pm 2^{\circ}\text{C}$
Length of test 96 hours

Results: There should be no stain on surface of products.
Frequency and wave form of tested products must remain within specifications.

2) Aging test

Conditions: Temperature $+85^{\circ}\text{C} \pm 20^{\circ}\text{C}$
Length of test 96 hours

Results: Deviation of frequency must be less than $\pm 3\text{ppm}$

3) Salt spray test

Conditions: Temperature $+35^{\circ}\text{C} \pm 2^{\circ}\text{C}$
Length of test 48 hours
NaCl % 5%

Results: There should be no stain on surface of products.

4) Humidity test

Conditions: Temperature $+40^{\circ}\text{C} \pm 2^{\circ}\text{C}$
Relative humidity 90 - 95%
Length of test 96 hours

Results: a. Insulation resistance must be $500\text{ M}\Omega/100\text{ Vac}$. minimum
b. Resistance and wave form must remain within specifications.

Copyright © Each Manufacturing Company.

All Datasheets cannot be modified without permission.

This datasheet has been download from :

www.AllDataSheet.com

100% Free DataSheet Search Site.

Free Download.

No Register.

Fast Search System.

www.AllDataSheet.com